

SEAT PRESSURE - WALL MOUNTING PENSTOCK

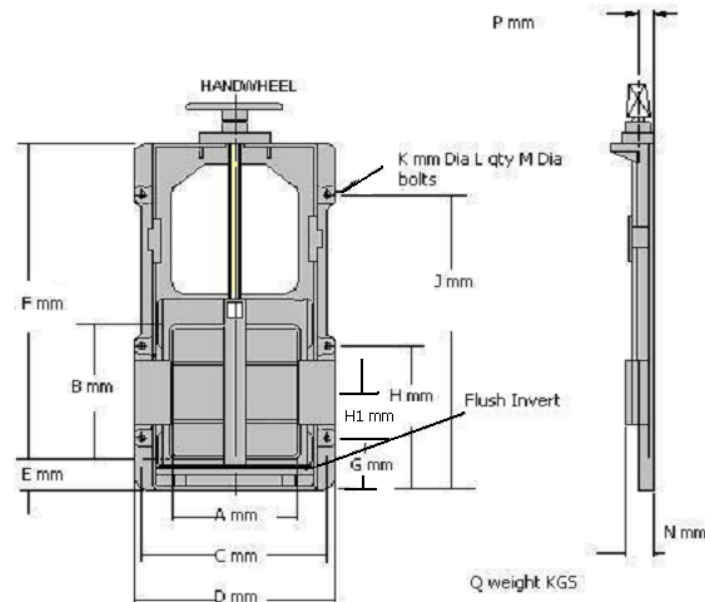

| A-B | C | D | E | F | G | H1 | H | J | K | L | M | N | O | Q |
|-----|-----|-----|----|------|----|-----|-----|------|----|---|----|-----|-----|-----|
| 150 | 300 | 345 | 55 | 399 | 55 | - | 215 | 365 | 15 | 6 | 12 | 115 | 67 | 22 |
| 200 | 350 | 395 | 55 | 520 | 55 | - | 235 | 435 | 15 | 6 | 12 | 115 | 67 | 38 |
| 225 | 375 | 420 | 55 | 549 | 55 | - | 255 | 495 | 15 | 6 | 12 | 115 | 67 | 42 |
| 250 | 400 | 445 | 55 | 629 | 55 | - | 420 | 649 | 15 | 6 | 12 | 54 | 65 | 43 |
| 300 | 450 | 495 | 55 | 729 | 55 | - | 440 | 694 | 15 | 6 | 12 | 54 | 65 | 54 |
| 400 | 565 | 619 | 75 | 953 | 75 | - | 485 | 995 | 15 | 6 | 12 | 130 | 97 | 78 |
| 450 | 615 | 670 | 75 | 1055 | 75 | 230 | 230 | 1085 | 15 | 8 | 12 | 130 | 97 | 110 |
| 500 | 665 | 720 | 75 | 1155 | 75 | 225 | 225 | 1130 | 15 | 8 | 12 | 135 | 97 | 128 |
| 600 | 765 | 820 | 75 | 1355 | 75 | 305 | 305 | 1390 | 15 | 8 | 12 | 140 | 102 | 149 |

Castings Services Limited
 Head Office & Valve Division
 Langley Road South, Salford
 Manchester, England. M6 6TZ



Pipeline Sales Office
 Unit 7, Oaktree Business Park
 Cadley Hill Road, Swadlincote
 Derbyshire. DE11 9DJ

Tel : 00 44 (0) 161 745 9095
 Fax: 00 44 (0) 161 745 8996

E-Mail: sales@castings-services.co.uk

Tel : 00 44 (0) 1283 554720
 Fax: 00 44 (0) 1283 554721

Web: www.castings-services.co.uk

Castings Services reserve the right to make any design modifications without giving prior notice. E & O E.

Document Ref: VZPEN.01

All Penstocks can be manufactured in the following trim and with the coating systems

| Penstock Component | Material | British Standard |
|-----------------------------|------------------------|-------------------------|
| Frames | Mild Steel | BS4360 Gr43A |
| | Stainless Steel | BS970 Gr304/Gr316 |
| | Cast Iron | BS1452 Gr220 |
| Doors & Wedges | HDPE Solid plastic | |
| | Stainless Steel | BS970 Gr304/316 |
| | Cast Iron | BS1452 Gr220 |
| Operating Stems | Stainless Steel | BS970 Gr316 |
| Thrust Nuts & Drive Sleeves | Stainless Steel | BS970 Gr316 |
| | Gunmetal | BS1400 GrLG2 |
| | Phosphor Bronze | BS2874 PB102 |
| | High Tensile Brass | BS1400 HTB1 |
| Thrust Housings, Caps | Stainless Steel | BS970 Gr304/316 |
| | Cast Iron | BS1452 Gr220 |
| Hand wheels | Cast Iron | BS1452 Gr220 |
| | Cast Aluminium | BS1490 |
| Assembly Fasteners | Stainless Steel | BS970 Gr. A2, A4 |
| Frame Gate Seal | Phosphor Bronze | BS2874 PB102 |
| Flush Invert | EPDM | ASTM2000 |

Painting Guidelines.

No consideration is required for the paint coating of the SG range of penstocks, one only consideration one has is to think of the floor pillar and coping brackets, as all doors and frames are stainless steel throughout and therefore require no further treatment to their natural finish. (Aesthetic finishes can be applied when required) It is normal practice to either galvanise or flame zinc spray mild steel to achieve a good base protection prior to epoxy coating. Where epoxy is specified it is preferable to blast clean, zinc spray, etch prime and then apply the epoxy coating to the desired DFT. For potable water applications it is wise to seek advice from the DWI for approved coatings or follow, the customers specification which will normally state the requirements for DFT, number of coats etc.

Where no particular specifications are evident, the following guidelines can be applied:

Mild Steel:

Sewage - Blast clean, HD galvanise to BS729.

Blast clean, zinc spray, etch prime, coal tar epoxy to 150 microns DFT.

Potable - Blast clean, zinc spray, etch prime, bitumen to 150 microns DFT.

Blast cleaning should be to Swedish Standard SA2.5 Zinc spraying to Zn4 - 100 microns nominal, 75 microns minimum

Castings Services Limited
Head Office & Valve Division
Langley Road South, Salford
Manchester, England. M6 6TZ



Pipeline Sales Office

Unit 7, Oaktree Business Park
Cadley Hill Road, Swadlincote
Derbyshire. DE11 9DJ

Tel : 00 44 (0) 161 745 9095

Fax: 00 44 (0) 161 745 8996

E-Mail: sales@castings-services.co.uk

Web: www.castings-services.co.uk

Tel : 00 44 (0) 1283 554720

Fax: 00 44 (0) 1283 554721

Castings Services reserve the right to make any design modifications without giving prior notice. E & O E.

Document Ref: VZPEN.01