

## DF Recoil Type Check Valve

( Non Slam Type )

Size Range : 100mm - 1000mm

### Key Features

- ◆ Ductile Iron Body & Cover -GGG50
- ◆ Ductile Iron Disc & Arm - GGG50
- ◆ Stainless steel shaft X20Cr13.
- ◆ Bronze / Stainless Steel 316 Seats
- ◆ Angled Disc for more rapid closing  
- Ideal for high fluid velocities  
exceeding 4m/sec.
- ◆ Vent & drain plug fitted as  
standard.
- ◆ Compact Design.
- ◆ Flanged PN16 as standard with  
supporting body feet.
- ◆ WRAS Approved Epoxy Coating



Available Ex-Stock in sizes u.t.i 300mm

### Options:

- \* Flanges can be drilled PN10 or ANSI.
- \* PN25 available upon request.
- \* Can be supplied with a by-pass.
- \* Can be fitted with a microswitch

Note: Options subject to agreed lead times  
and must be specified at order  
placement.

**Castings Services Limited**  
Head Office & Valve Division  
Langley Road South, Salford  
Manchester, England. M6 6TZ

Tel : 00 44 (0) 161 745 9095  
Fax: 00 44 (0) 161 745 8996



E-Mail: [sales@castings-services.co.uk](mailto:sales@castings-services.co.uk)

Web: [www.castings-services.co.uk](http://www.castings-services.co.uk)

### Pipeline Sales Office

Unit 7, Oaktree Business Park  
Cadley Hill Road, Swadlincote  
Derbyshire. DE11 9DJ

Tel : 00 44 (0) 1283 554720  
Fax: 00 44 (0) 1283 554721

## Metal Faced Recoil Type Check Valve

(Non Slam Type) Flanged PN16

Size Range : 100mm - 1000mm

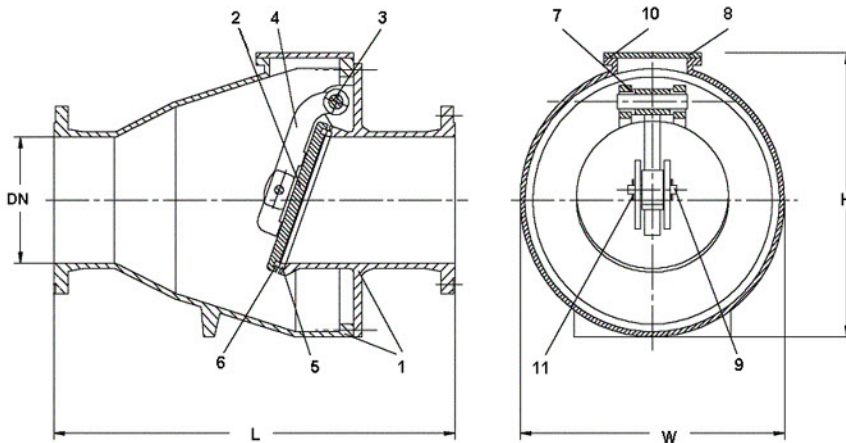

	Description	Material
1	Body & Inlet	Ductile Iron GGG50
2	Disc	Ductile Iron GGG50
3	Shaft	Stainless Steel X20Cr13
4	Arm	Ductile Iron GGG50
5	Body Seat	Bronze BS1400 LG2
6	Disc Seat	Stainless Steel Gr 316L
7	Bearing	Bronze BS1400 LG2
8	Cover	Ductile Iron GGG50
9	Hinge Pin	Stainless Steel Gr 420
10	O-Rings	EPDM
11	Locking pins	Stainless Steel Gr.316

DN (mm)	Face -Face L mm	Height H mm	Width W mm	Approx Weight KG
100mm	460	325	290	95
150mm	610	470	430	175
200mm	762	560	520	250
250mm	965	600	556	380
300mm	1067	715	670	450
350mm	1143	880	832	625
400mm	1143	890	838	857
450mm	1219	1020	970	1050
500mm	1321	1090	1040	1450
600mm	1450	1190	1130	1838
700mm	1580	1280	1210	2513
800mm	1700	1370	1300	3125
900mm	1840	1470	1390	4200
1000mm	1985	1570	1490	5600

For Recoil Valves above 1000mm or any other technical queries - Please refer to our Valve Division : Tel: 0161 745 9095  
 Note - Valves are recommended for horizontal installation, but can be manufactured to suit vertical pipe installation.

**Castings Services Limited**  
 Head Office & Valve Division  
 Langley Road South, Salford  
 Manchester, England. M6 6TZ

Tel : 00 44 (0) 161 745 9095  
 Fax: 00 44 (0) 161 745 8996



E-Mail: [sales@castings-services.co.uk](mailto:sales@castings-services.co.uk)

Web: [www.castings-services.co.uk](http://www.castings-services.co.uk)

### Pipeline Sales Office

Unit 7, Oaktree Business Park  
 Cadley Hill Road, Swadlincote  
 Derbyshire. DE11 9DJ

Tel : 00 44 (0) 1283 554720  
 Fax: 00 44 (0) 1283 554721

Castings Services reserve the right to make any design modifications without giving prior notice. E & O E.

Document Ref: VZRECOIL.01