

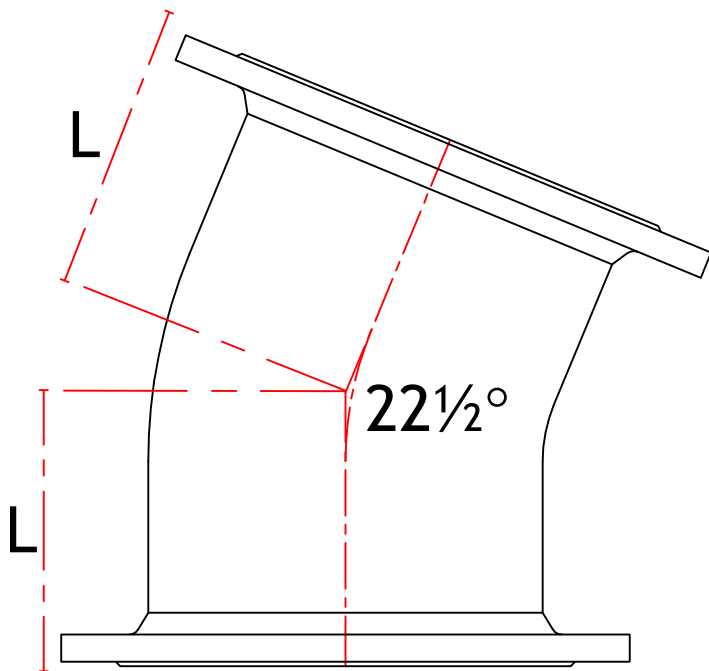

DOUBLE FLANGED

F2.1

22.5 DEG BEND

CLASS K12
STANDARD
BS EN 545/598 ISO 2531

OPTIONS

- EN598
- EN545

Diameter (mm)	Length 'L' (mm)	Weight (Kg)	CSG Reference
80	130	9.3	F080B22
100	140	11.5	F100B22
150	160	18.6	F150B22
200	180	27	F200B22
250	350	55	F250B22
300	400	78	F300B22
350	298	83	F350B22
400	324	108	F400B22
450	349	138	F450B22
500	375	177	F500B22
600	426	268	F600B22
700	478	329	F700B22
800	529	447	F800B22
900	581	577	F900B22
1000	632	760	FZ10B22

Please remember to order gaskets

Technical drawings for illustrative purposes only. Actual product may be subject to minor design changes without notice.

Head Office

Langley Road South,
Salford,
Manchester M6 6TZ

T: +44 (0) 161 745 9095

F: +44 (0) 161 745 8996