

C250 DUCTILE IRON HINGED GRATE AND FRAME

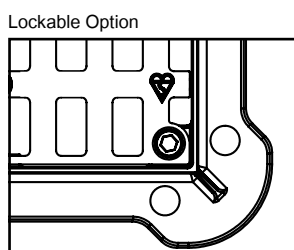
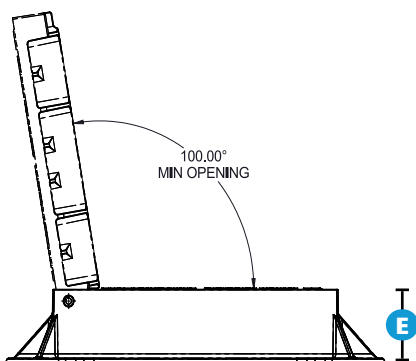
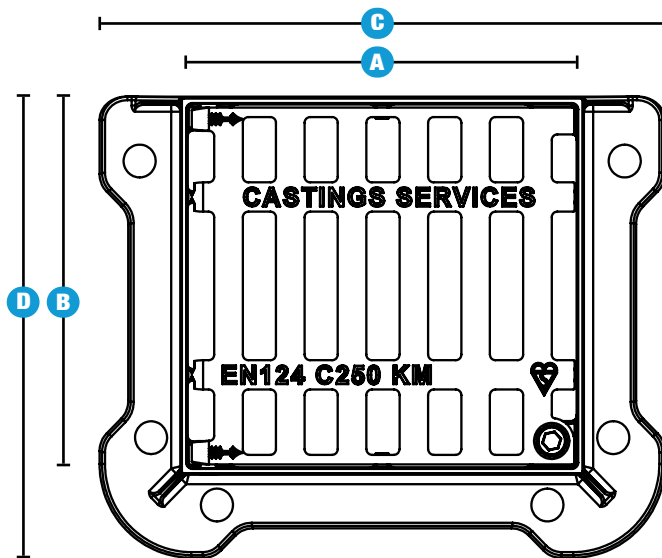
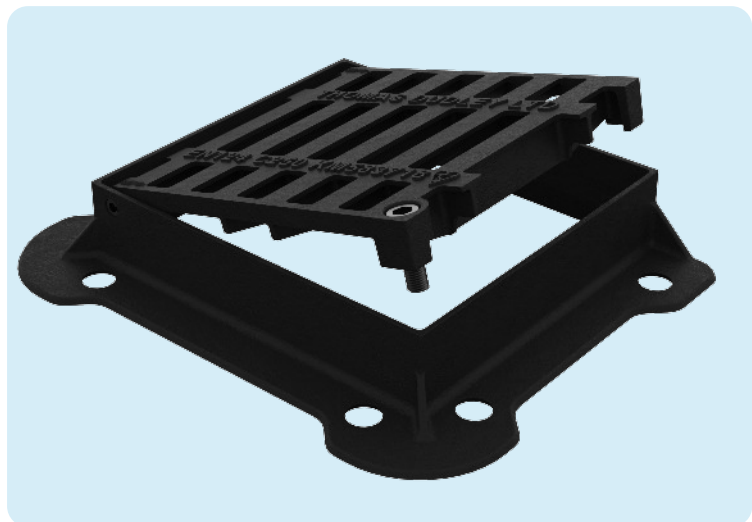

Clear Opening (A x B)	Over Fame (C x D)	Depth (E)	Product Code
340 x 310	494 x 394	75	GDC3431EH10/T
340 x 310	494 x 394	75	GDC3431EH10LKG/T

Key Features:

- Anti-theft design
- Hinged for traffic flow
- BSEN124-2:2015 compliant.
- Suitable for kerb side traffic areas.
- Designed to last, not just pass the EN124 test.
- Quality assured UK engineering.



BSI
Certified



EN124-2
Compliant

UK
Engineering

C250
Group 3

Sales Office **0161 745 9095**
 Telecom Products **0161 907 1242**
 Pipelines **0161 907 1241**
 Email sales@castings-services.co.uk
www.castings-services.co.uk

