

D400 DUCTILE IRON HINGED GRATE AND FRAME

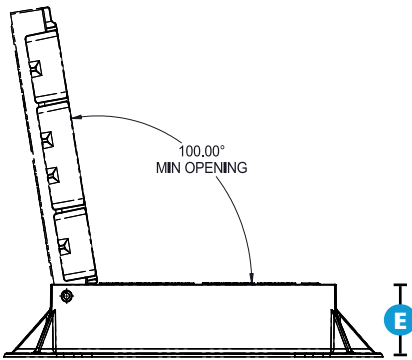

Lockable Option

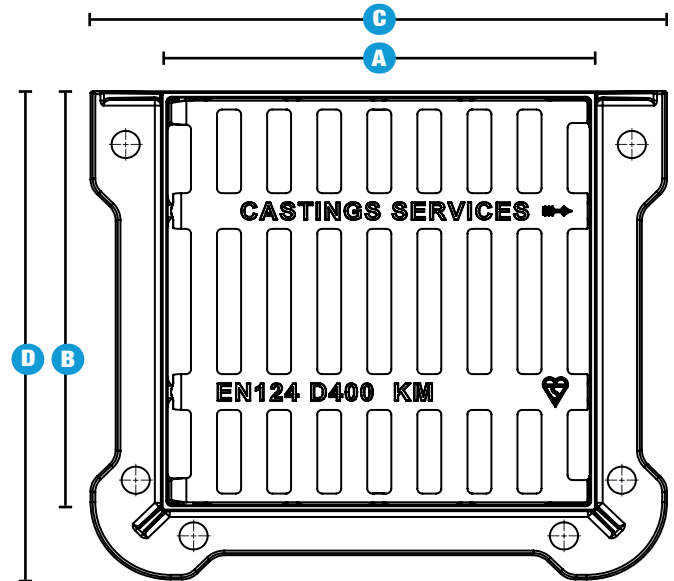
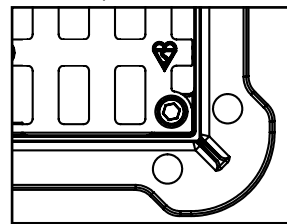

Key Features:

- Anti-theft design
- Hinged for traffic flow
- HA104/09 and BSEN124-2:2015 compliant.
- Suitable for high intensity traffic areas.
- Designed to last, not just pass the EN124 test.
- Quality assured UK engineering.

| Clear Opening (A x B) | Over Fame (C x D) | Depth (E) | Product Code |
|-----------------------|-------------------|-----------|------------------|
| 420 x 420 | 574 x 505 | 100 | GDD4242EH10/T |
| 430 x 370 | 590 x 459 | 100 | GDD4337EH10/T |
| 360 x 310 | 519 x 395 | 100 | GDD3631EH10/T |
| 360 x 310 | 519 x 395 | 100 | GDD36310EHLKG/T* |

*Locked Option



BSI
Certified



EN124-2
Compliant



HA104/09
Compliant

D400
Group 4

Sales Office **0161 745 9095**
 Telecom Products **0161 907 1242**
 Pipelines **0161 907 1241**
 Email sales@castings-services.co.uk
www.castings-services.co.uk



D400 DUCTILE IRON HINGED DOUBLE TRIANGLE GRATE AND FRAME

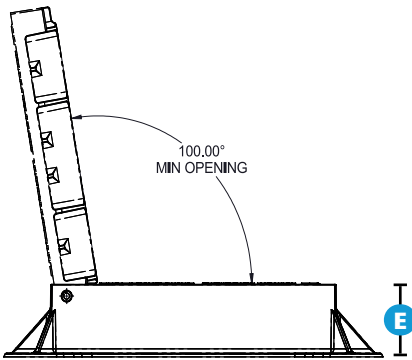
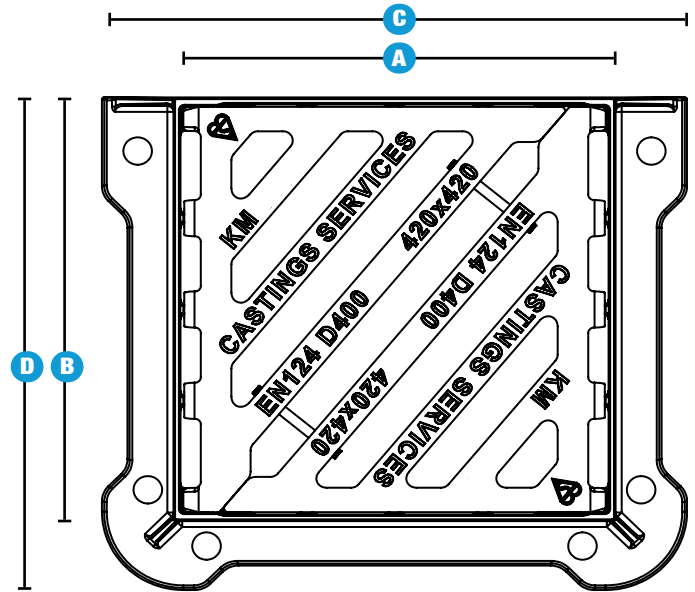

Key Features:

- Anti-theft design
- Hinged for traffic flow
- Double triangular - Non rock
- HA104/09 and BSEN124-2:2015 compliant.
- Suitable for high intensity traffic areas.
- Designed to last, not just pass the EN124 test.
- Quality assured UK engineering.

| Clear Opening (A x B) | Over Fame (C x D) | Depth (E) | Product Code |
|-----------------------|-------------------|-----------|-----------------|
| 420 x 420 | 574 x 505 | 100 | GDD4242EHDT10/T |
| 600 x 600 | 750 x 750 | 100 | GDD6060EHDT10/T |



BSI
Certified



EN124-2
Compliant



HA104/09
Compliant

D400
Group 4

Sales Office **0161 745 9095**
 Telecom Products **0161 907 1242**
 Pipelines **0161 907 1241**
 Email sales@castings-services.co.uk
www.castings-services.co.uk

