



# DOUBLE FLANGED

F1.1

## 11.25 DEG BEND

CLASS K12

STANDARD

BS EN 545/598 ISO 2531

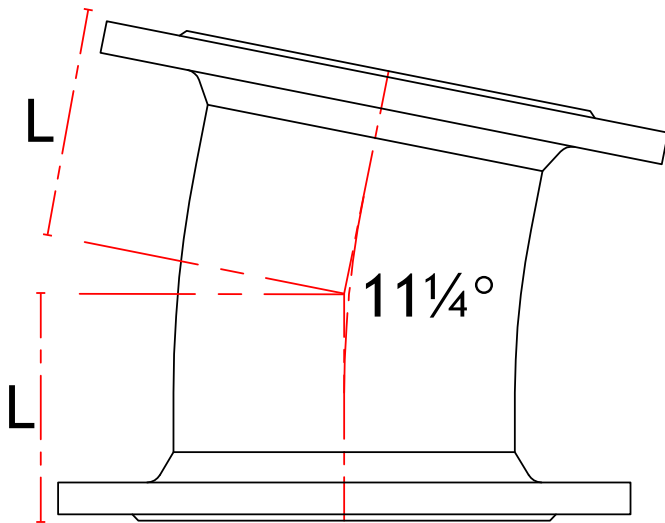

### OPTIONS

- EN598
- EN545

Diameter (mm)	Length 'L' (mm)	Weight (Kg)	CSG Reference
80	130	9.3	F080B11
100	140	11.5	F100B11
150	160	19	F150B11
200	180	28	F200B11
250	350	55	F250B11
300	400	78	F300B11
350	298	84	F350B11
400	324	109	F400B11
450	349	139	F450B11
500	375	179	F500B11
600	426	269	F600B11
700	478	336	F700B11
800	529	455	F800B11
900	581	584	F900B11
1000	632	773	FZ10B11

Please remember to order gaskets

Technical drawings for illustrative purposes only. Actual product may be subject to minor design changes without notice.



#### Head Office

Langley Road South,  
Salford,  
Manchester M6 6TZ

T: +44 (0) 161 745 9095

F: +44 (0) 161 745 8996