



# FLANGED CROSS

F11.1

CLASS K12

STANDARD

BS EN 545/598 ISO 2531

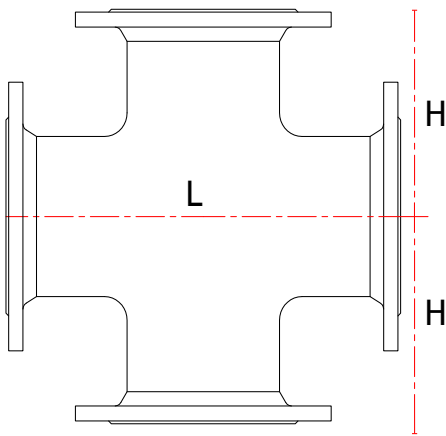

Diameter (mm)	Length 'L' (mm)	Height 'H' (mm)	Weight (Kg)	CSG Reference
80	330	165	20.5	F080X
100	360	180	24.5	F100X
150	440	220	41	F150X
200	520	260	61	F200X
250	700	350	100	F250X
300	800	400	143	F300X
350	850	425	189	F350X
400	900	450	236	F400X
450	950	475	286	F450X
500	1000	500	370	F500X
600	1100	550	542	F600X

## OPTIONS

- EN598
- EN545

Please remember to order gaskets

Technical drawings for illustrative purposes only. Actual product may be subject to minor design changes without notice.



Head Office  
Langley Road South,  
Salford,  
Manchester M6 6TZ

T: +44 (0) 161 745 9095  
F: +44 (0) 161 745 8996