



FLANGED TAPER

F16.1

CONCENTRIC

CLASS K12

STANDARD

BS EN 545/598 ISO 2531

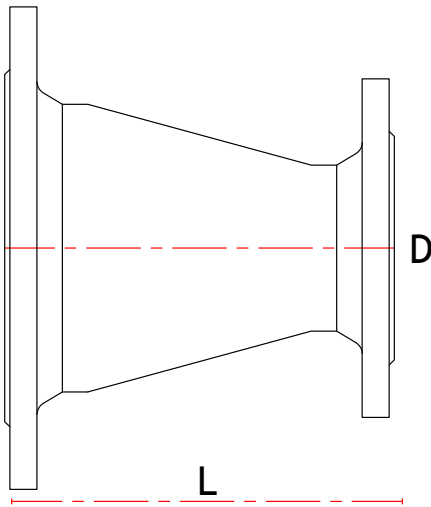

Diameter (mm)	Diameter 'D' (mm)	Length 'L' mm				Weight (Kg)	CSG
		DIN	ISO	EN Series A	EN Series B		
80	50	200	200	200		7.3	F080CT050
100	50	200	300	300		9.4	F100CT050
100	80	200	200	200	195	9.3	F100CT080
150	80	200	400	400	260	16.1	F150CT080
150	100	200	300	300	220	15	F150CT100
200	80	300	600	600	390	25.5	F200CT080
200	100	300	600	600	330	27	F200CT100
200	150	300	300	300	235	21.5	F200CT150
250	100	300	600	600	455	34	F250CT100
250	150	300	600	600	345	38	F250CT150
250	200	300	300	300	250	29.5	F250CT200
300	150	300	600	600	560	46	F300CT150
300	200	300	600	600	470	51	F300CT200
300	250	300	300	300	360	39.5	F300CT250
350	200	300	650	650	265	60.5	F350CT200
350	250	300	600	600		67	F350CT250
350	300	300	300	300		52	F350CT300
400	200	300	700	700		71	F400CT200
400	250	300	650	650		77	F400CT250
400	300	300	600	600		84	F400CT300
400	350	300	300	300		67	F400CT350

OPTIONS

- EN598
- EN545

Please remember to order gaskets

Technical drawings for illustrative purposes only. Actual product may be subject to minor design changes without notice.



Head Office

Langley Road South,
Salford,
Manchester M6 6TZ

T: +44 (0) 161 745 9095
F: +44 (0) 161 745 8996