



# ANGLE BRANCH

F17.1

## DOUBLE FLANGED

CLASS K12

STANDARD

BS EN 545/598 ISO 2531

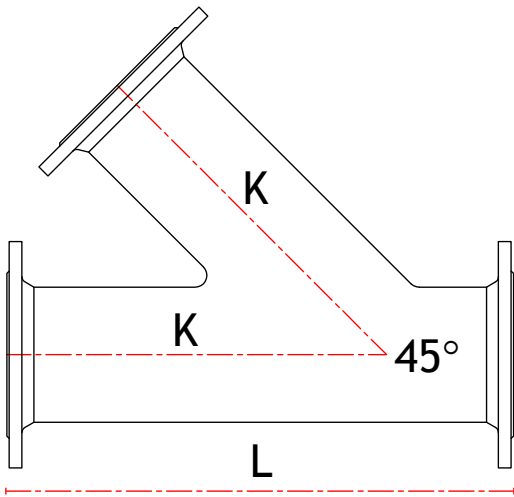

Diameter	Branch Diameter	Length 'L'	Length 'K'	Weight	CSG
(mm)	(mm)	(mm)	(mm)	(Kg)	
80	80	500	375	21	F080AB
100	100	540	405	27	F100AB
150	150	640	480	47	F150AB
200	200	735	560	71	F200AB
250	250	830	640	104	F250AB
300	300	930	715	146	F300AB
350	350	880	790	170	F350AB
400	400	970	870	220	F400AB
450	450	1060	950	290	F450AB
500	500	1140	1025	360	F500AB
600	600	1310	1180	590	F600AB

### OPTIONS

- EN598
- EN545

Please remember to order gaskets

Technical drawings for illustrative purposes only. Actual product may be subject to minor design changes without notice.



#### Head Office

Langley Road South,  
Salford,  
Manchester M6 6TZ

T: +44 (0) 161 745 9095

F: +44 (0) 161 745 8996