



RADIAL 'T'

F20.1

FLANGED

CLASS K12

STANDARD

BS EN 545/598 ISO 2531

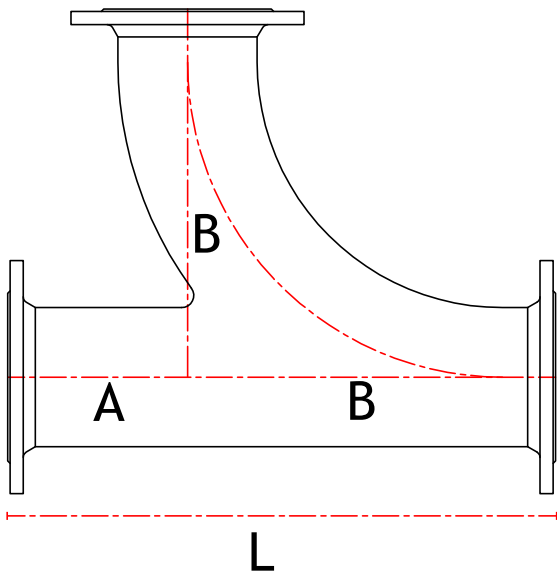

Dimension	Length 'L'	Dimension 'A'	Dimension 'B'	Weight	CSG Reference
(mm)	(mm)	(mm)	(mm)	(Kg)	
80	545	165	380	23	F080TR
100	580	180	400	30	F100TR
150	670	220	450	48	F150TR
200	760	260	500	73	F200TR
250	900	350	550	106	F250TR
300	1000	400	600	146	F300TR
350	1100	450	650	204	F350TR
400	1200	500	700	263	F400TR
450	1300	550	750	332	F450TR
500	1400	600	800	422	F500TR
600	1600	700	900	624	F600TR

OPTIONS

- EN598
- EN545

Please remember to order gaskets

Technical drawings for illustrative purposes only. Actual product may be subject to minor design changes without notice.



Head Office

Langley Road South,
Salford,
Manchester M6 6TZ

T: +44 (0) 161 745 9095

F: +44 (0) 161 745 8996