



BLANK FLANGES

F21.1

FLANGED PN10, PN16 OR PN25

CLASS K12

STANDARD

BS EN 545/598 ISO 2531

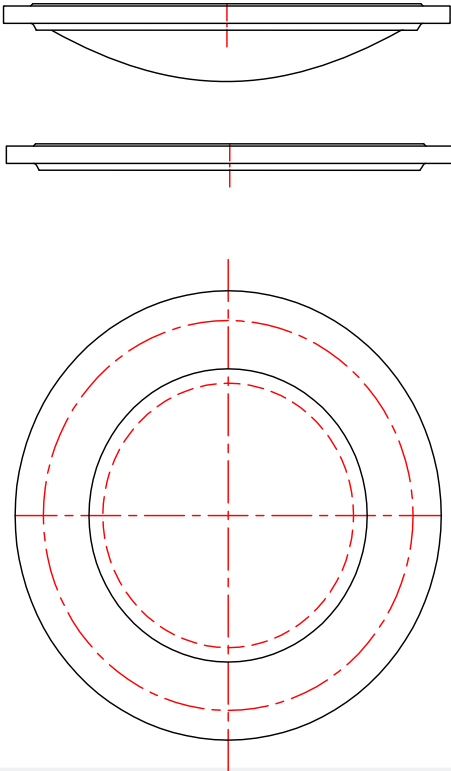

OPTIONS

- EN598
- EN545

Dimension	PN 10	PN 16	PN 25	CSG Reference
(mm)	(kg)	(kg)	(kg)	
80	3.9	3.9	3.9	F080BF
100	4.8	4.8	5.1	F100BF
150	8.1	8.1	8.8	F150BF
200	11.6	11.4	13.3	F200BF
250	16.9	16.6	21	F250BF
300	24	23.5	30	F300BF
350	31	34.5	45	F350BF
400	38	46	60	F400BF
450	50	62	81	F450BF
500	58	79	97	F500BF
600	89	125	149	F600BF
700	128	165	215	F700BF
800	180	229	304	F800BF
900	236	296	397	F900BF
1000	305	399	535	FA10BF
1100	405	518	670	FA11BF
1200	575	662	850	FA12BF
1400	745	995	1350	FA14BF
1600	1255	1460	1940	FA16BF

Please remember to order gaskets

Technical drawings for illustrative purposes only. Actual product may be subject to minor design changes without notice.

Head Office

Langley Road South,
Salford,
Manchester M6 6TZ

T: +44 (0) 161 745 9095

F: +44 (0) 161 745 8996