

DOUBLE FLANGED

F3.1

45 DEG BEND

CLASS K12

STANDARD	BS EN 545/598 ISO 2531
----------	------------------------

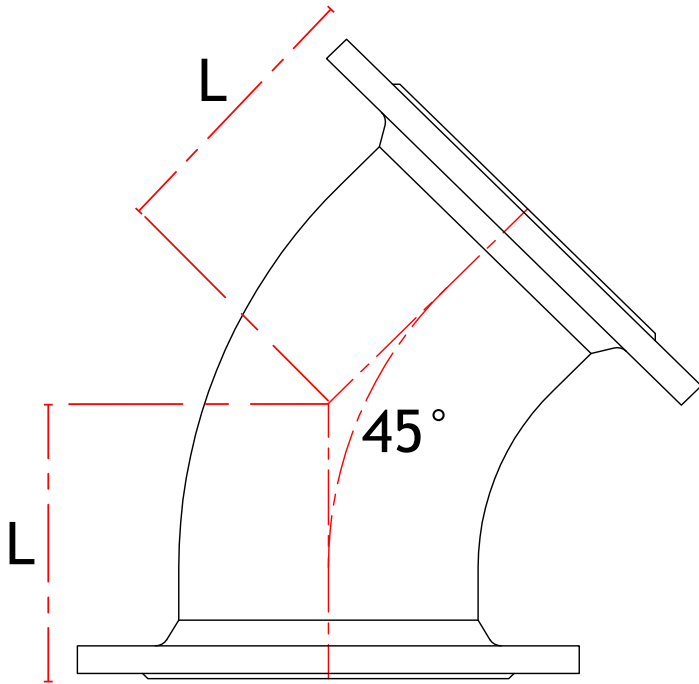

Diameter (mm)	Length 'L' (mm)	Weight (Kg)	CSG Reference
80	130	9.5	F080B45
100	140	11.3	F100B45
150	160	18.3	F150B45
200	180	27	F200B45
250	350	54	F250B45
300	400	76	F300B45
350	298	84	F350B45
400	324	109	F400B45
450	349	135	F450B45
500	375	175	F500B45
600	426	263	F600B45
700	478	328	F700B45
800	529	444	F800B45
900	581	569	F900B45
1000	632	753	FZ10B45

OPTIONS

- EN598
- EN545

Please remember to order gaskets

Technical drawings for illustrative purposes only. Actual product may be subject to minor design changes without notice.



Head Office
 Langley Road South,
 Salford,
 Manchester M6 6TZ
T: +44 (0) 161 745 9095
F: +44 (0) 161 745 8996