



DOUBLE FLANGED

F4.1

90 DEG BEND

CLASS K12

STANDARD

BS EN 545/598 ISO 2531

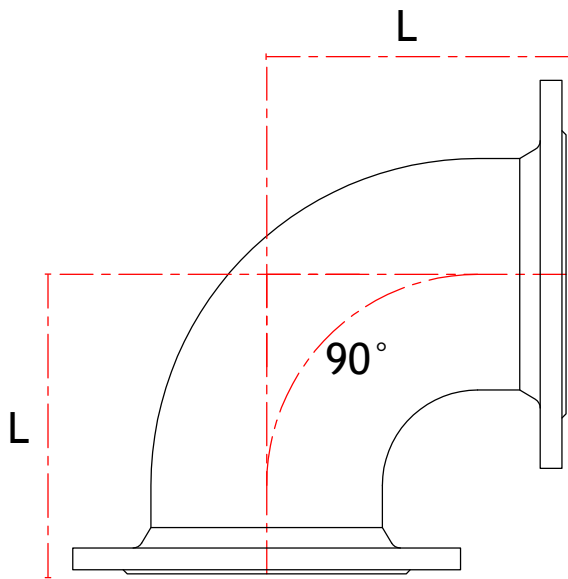

OPTIONS

- EN598
- EN545

Diameter (mm)	Length 'L' (mm)	Weight (Kg)	CSG Reference
80	165	9.6	F080B90SR
100	180	12	F100B90SR
150	220	20.5	F150B90SR
200	260	31	F200B90SR
250	350	49.5	F250B90SR
300	400	69	F300B90SR
350	450	96	F350B90SR
400	500	126	F400B90SR
450	550	163	F450B90SR
500	600	211	F500B90SR
600	700	324	F600B90SR
700	800	418	F700B90SR
800	900	573	F800B90SR
900	1000	746	F900B90SR
1000	1100	988	FZ10B90SR

Please remember to order gaskets

Technical drawings for illustrative purposes only. Actual product may be subject to minor design changes without notice.



Head Office

Langley Road South,
Salford,
Manchester M6 6TZ

T: +44 (0) 161 745 9095

F: +44 (0) 161 745 8996