

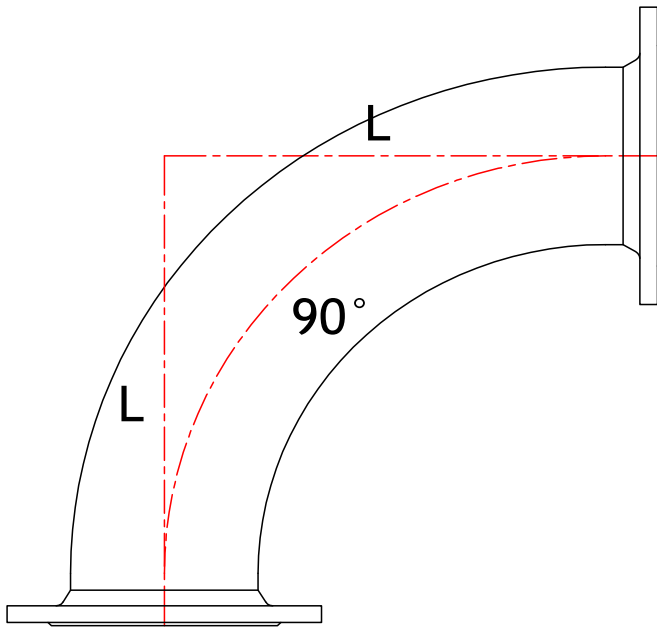

DOUBLE FLANGED

F5.1

90 DEG BEND (LONG RADIUS)

CLASS K12
STANDARD
BS EN 545/598 ISO 2531

OPTIONS

- EN598
- EN545

Diameter (mm)	Length 'L' (mm)	Weight (Kg)	CSG Reference
80	380	15	F080B90LR
100	400	18	F100B90LR
150	450	31	F150B90LR
200	500	46	F200B90LR
250	550	66	F250B90LR
300	600	91	F300B90LR
350	650	122	F350B90LR
400	700	158	F400B90LR
450	750	200	F450B90LR
500	800	254	F500B90LR
600	900	379	F600B90LR
700	1000	489	F700B90LR
800	1100	661	F800B90LR
900	1200	854	F900B90LR
1000	1300	1117	FZ10B90LR

Please remember to order gaskets

Technical drawings for illustrative purposes only. Actual product may be subject to minor design changes without notice.



Head Office
Langley Road South,
Salford,
Manchester M6 6TZ

T: +44 (0) 161 745 9095
F: +44 (0) 161 745 8996